

### ZASTOSOWANIE

Wentylatory EGT odpowiadają wymaganiom Dyrektywy ATEX 2014/34/UE, są zaprojektowane do użytku w strefach zagrożenia wybuchem poza kopalniami i wyrobiskami górniczymi, spełniają wymogi grupy II kategorii 2G/3G – strefa 1 i/lub 2 oraz kategorii 2D/3D – strefa 21 i/lub 22.

### Oznaczenia ATEX:

II 2G Ex h IIB T3 Gb lub II 2D Ex h IIIC T125°C Db

II 2G Ex h IIB T4 Gb na życzenie

### KONSTRUKCJA

- średniociśnieniowy wentylator promieniowy o napędzie bezpośrednim,
- wirnik odlewany ze stopu aluminium (dla urządzeń kategorii 2G) lub spawany z blachy stalowej (dla urządzeń kategorii 2D) z łopatkami prostymi, wyważony dynamicznie wg ISO 1940-1,
- obudowa spawana z blachy stalowej,
- statyw w modelach do wielkości 300,
- podstawa silnika w modelach od wielkości 400,
- osłona wlotu i wylotu ocynkowana,
- wentylator malowany na kolor czarny RAL 9005 (kategoria korozyjności C3),
- maksymalna temperatura tłoczonego medium 60°C,
- figura LG270.

### SILNIK ELEKTRYCZNY

- przeciwwybuchowy, asynchroniczny trójfazowy 230/400V, 50Hz lub 400/690V 50Hz (w zależności od modelu),
- stopień ochrony IP55 (w wentylatorach kategorii 2G),
- stopień ochrony IP65 lub IP66 (w wentylatorach kategorii 2D w zależności od modelu),
- stopień ochrony IP66 (w wentylatorach 2G i 2D przystosowanych do regulacji częstotliwościowej),
- klasa izolacji F,
- zabezpieczenie termiczne PTC (w zależności od modelu oraz silnik do regulacji częstotliwościowej),
- wersja VFD przystosowana do regulacji częstotliwościowej.

### WYKONANIA SPECJALNE

- dowolna figura LG/RD,
- malowanie na inny kolor niż standardowy,
- wirnik, obudowa i podstawa wentylatora z blachy stalowej nierdzewnej 1.4301,
- wirnik, obudowa i podstawa wentylatora z blachy stalowej kwasoodpornej 1.4404,
- silniki na inne niż standardowe napięcie oraz częstotliwość zasilania,
- silnik o innym stopniu ochrony IP,
- silnik wyposażony w czujniki,
- silnik na niższe prędkości obrotowe.

FIGURY

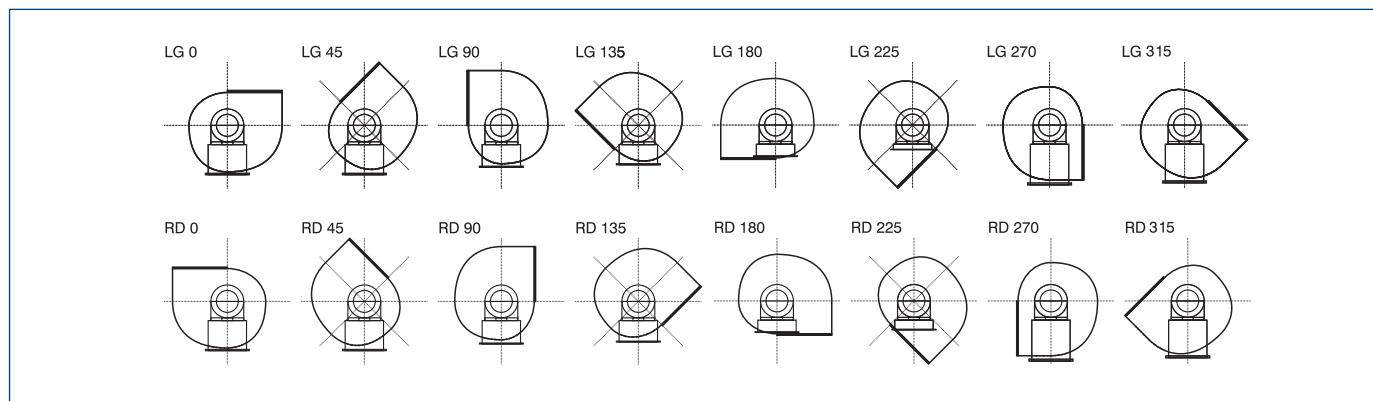

DANE TECHNICZNE

Typ	wydajność max	ciśnienie max	moc silnika	predkość obrotowa	natężenie (400V)	poziom ciśnienia akust.*	temperatura otoczenia min   max		masa	nr artykułu
	[m³/h]	[Pa]	[kW]	[obr/min]	[A]	[dB(A)]	[°C]		[kg]	
<b>II 2G Ex h IIB T3 Gb</b>										
EGT-2-60-037T	600	1280	0,37	2870	0,95	74	-20	40	17,6	425521000
EGT-2-60-037T VFD	600	1280	0,37	2890	1,13	74	-20	50	20,1	425521004
EGT-2-80-055T	1260	1250	0,55	2850	1,3	75	-20	40	19,7	425521010
EGT-2-80-055T VFD	1260	1250	0,55	2890	1,49	75	-20	50	21,2	425521014
EGT-2-100-075T	1190	1800	0,75	2890	1,8	79	-20	40	24	435521020
EGT-2-100-075T VFD	1190	1800	0,75	2885	1,59	79	-20	50	26,2	435521024
EGT-2-130-110T	1500	2000	1,1	2900	2,5	80	-20	40	25,4	435521030
EGT-2-130-110T VFD	1500	2000	1,1	2870	2,5	80	-20	50	26,3	435521034
EGT-2-200-110T	1610	2020	1,1	2900	2,5	81	-20	40	35	435521040
EGT-2-200-110T VFD	1610	2020	1,1	2870	2,5	81	-20	50	35,9	435521044
EGT-2-250-220T	2230	2370	2,2	2910	4,3	82	-20	40	44,4	435521050
EGT-2-250-220T VFD	2230	2370	2,2	2895	4,84	82	-20	50	44	435521054
EGT-2-300-220T	2790	2340	2,2	2910	4,3	82	-20	40	45,5	435521060
EGT-2-300-220T VFD	2790	2340	2,2	2895	4,84	82	-20	50	45,1	435521064
EGT-2-400-300T	3340	2200	3,0	2915	5,8	84	-20	40	59,6	435521070
EGT-2-400-300T VFD	3340	2200	3,0	2885	5,72	84	-20	50	61,6	435521074
EGT-2-500-400T	5380	2080	4,0	2925	7,4	85	-20	40	80,3	435521080
EGT-2-500-400T VFD	5380	2080	4,0	2935	7,64	85	-20	50	75,3	435521084
EGT-2-600-550T	5830	2300	5,5	2940	10	88	-20	40	105,9	435521090
EGT-2-600-550T VFD	5830	2300	5,5	2935	10,58	88	-20	50	93,9	435521094
EGT-2-700-750T	7500	3010	7,5	2940	13,3	91	-20	40	164,7	435521100
EGT-2-700-750T VFD	7500	3010	7,5	2935	14,2	91	-20	50	136,7	435521104
EGT-2-750-1100T	9260	2610	11,0	2945	19,3	82	-20	40	187,6	435521110
EGT-2-750-1100T VFD	9260	2610	11,0	2950	20,35	82	-20	50	201,6	435521114
EGT-2-800-1500T	11290	2540	15,0	2945	26,2	93	-20	40	219,7	435521120
EGT-2-800-1500T VFD	11290	2540	15,0	2950	27,56	93	-20	50	206,7	435521124
<b>II 2D Ex h IIIC T1250C Db</b>										
EGT-2-60-037T	600	1280	0,37	2870	0,95	74	-20	40	17,4	425521002
EGT-2-60-037T VFD	600	1280	0,37	2890	1,13	74	-20	50	20,1	425521005
EGT-2-80-055T	1260	1250	0,55	2850	1,3	75	-20	40	19,7	425521012
EGT-2-80-055T VFD	1260	1250	0,55	2890	1,49	75	-20	50	21,2	425521015
EGT-2-100-075T	1190	1800	0,75	2890	1,8	79	-20	40	24	435521022
EGT-2-100-075T VFD	1190	1800	0,75	2885	1,59	79	-20	50	26,2	435521025
EGT-2-130-110T	1500	2000	1,1	2900	2,5	80	-20	40	25,4	435521032
EGT-2-130-110T VFD	1500	2000	1,1	2870	2,5	80	-20	50	26,3	435521035
EGT-2-200-110T	1610	2020	1,1	2900	2,5	81	-20	40	35	435521042
EGT-2-200-110T VFD	1610	2020	1,1	2870	2,5	81	-20	50	35,9	435521045
EGT-2-250-220T	2230	2370	2,2	2910	4,3	82	-20	40	44,4	435521052
EGT-2-250-220T VFD	2230	2370	2,2	2895	4,84	82	-20	50	44	435521055
EGT-2-300-220T	2790	2340	2,2	2910	4,3	82	-20	40	45,5	435521062
EGT-2-300-220T VFD	2790	2340	2,2	2895	4,84	82	-20	50	45,1	435521065
EGT-2-400-300T	3340	2200	3,0	2915	5,8	84	-20	40	59,6	435521072
EGT-2-400-300T VFD	3340	2200	3,0	2885	5,72	84	-20	50	61,6	435521075
EGT-2-500-400T	5380	2080	4,0	2925	7,4	85	-20	40	80,3	435521082
EGT-2-500-400T VFD	5380	2080	4,0	2935	7,64	85	-20	50	75,3	435521085
EGT-2-600-550T	5830	2300	5,5	2940	10	88	-20	40	105,9	435521092
EGT-2-600-550T VFD	5830	2300	5,5	2935	10,58	88	-20	50	93,9	435521095
EGT-2-700-750T	7500	3010	7,5	2940	13,3	91	-20	40	164,7	435521102
EGT-2-700-750T VFD	7500	3010	7,5	2935	14,2	91	-20	50	136,7	435521105
EGT-2-750-1100T	9260	2610	11,0	2945	19,3	82	-20	40	187,6	435521112
EGT-2-750-1100T VFD	9260	2610	11,0	2950	20,35	82	-20	50	201,6	435521115
EGT-2-800-1500T	11290	2540	15,0	2945	26,2	93	-20	40	219,7	435521122
EGT-2-800-1500T VFD	11290	2540	15,0	2950	27,56	93	-20	50	206,7	435521125

\* pomiar wykonany w odległości 1,5m od wentylatora, dla Q=2/3\*Qmax.

CHARAKTERYSTYKI PRACY

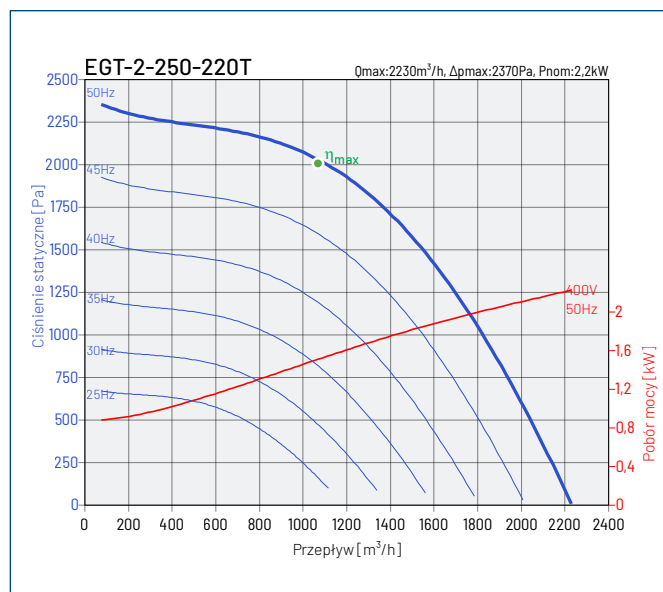
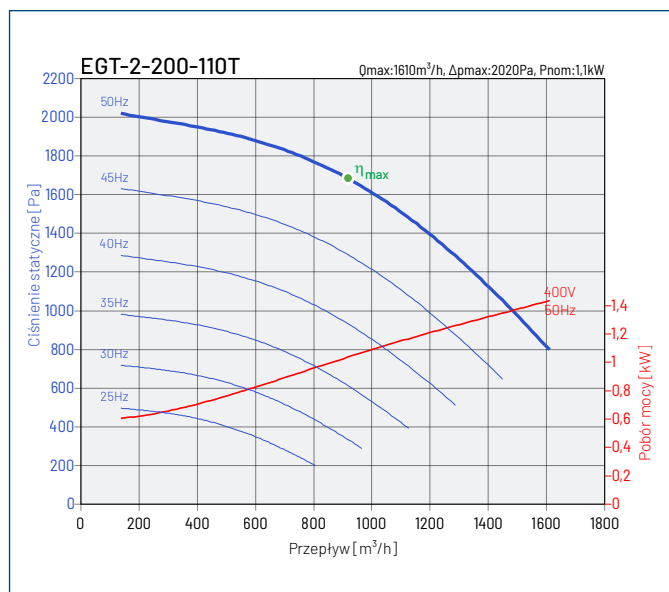
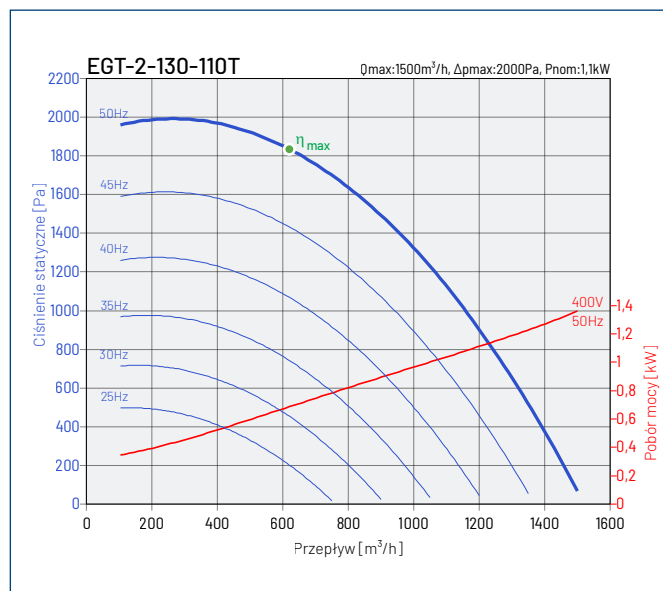
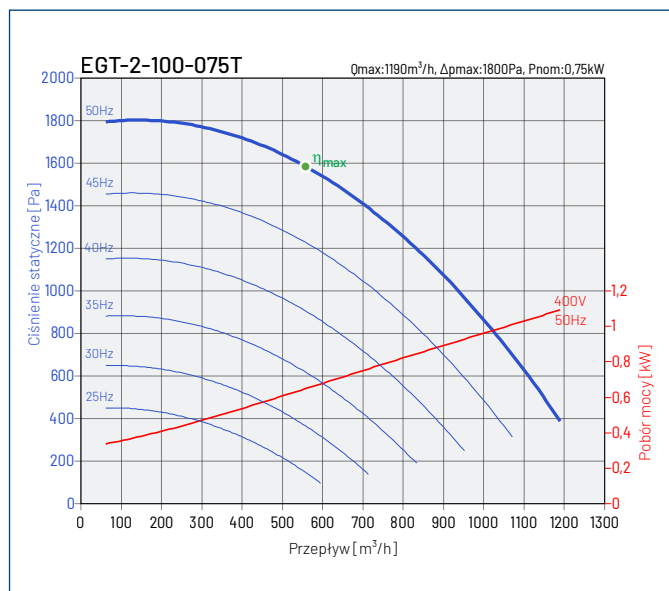
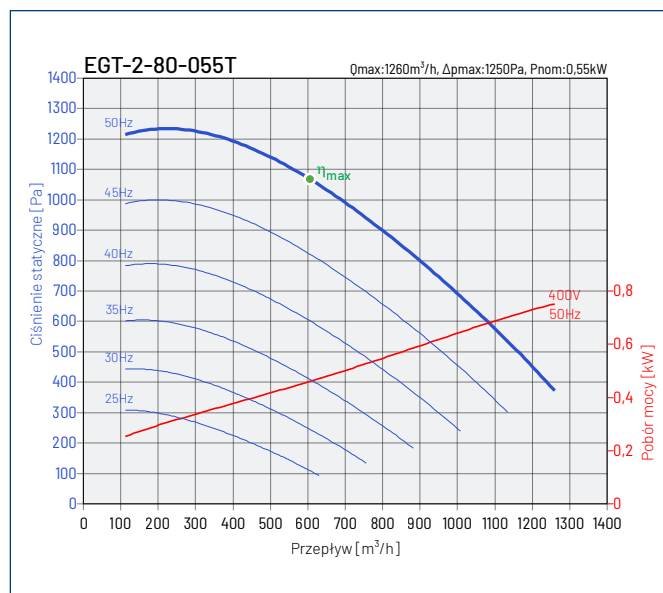
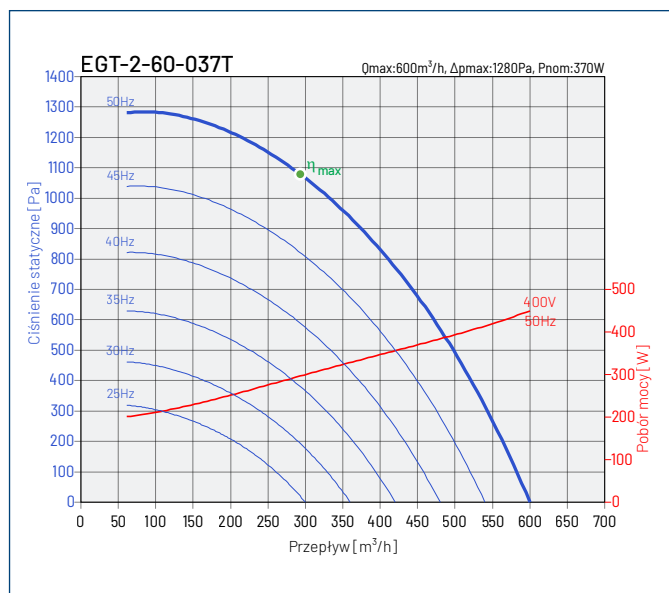

CHARAKTERYSTYKI PRACY

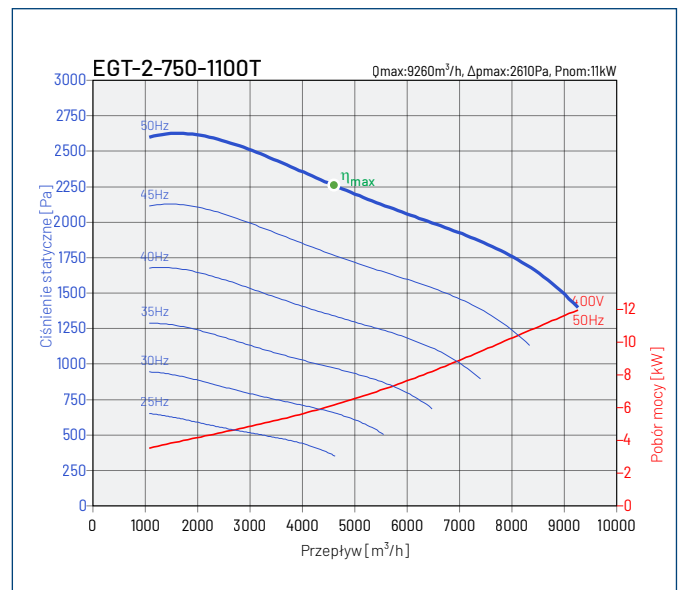
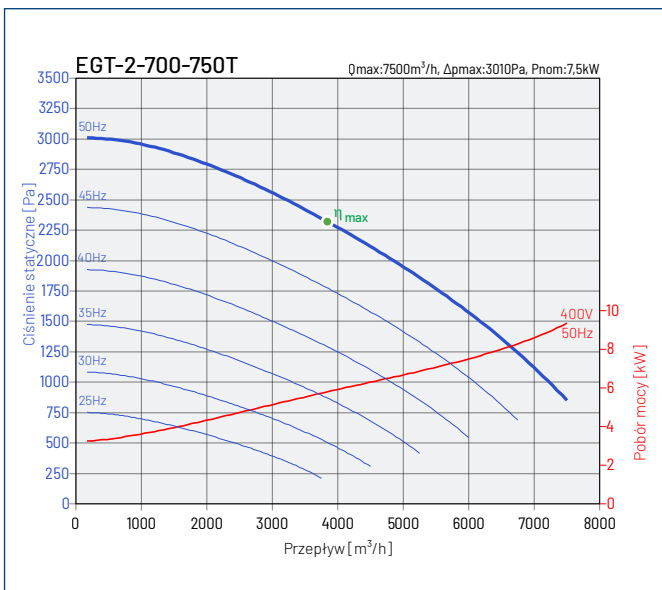
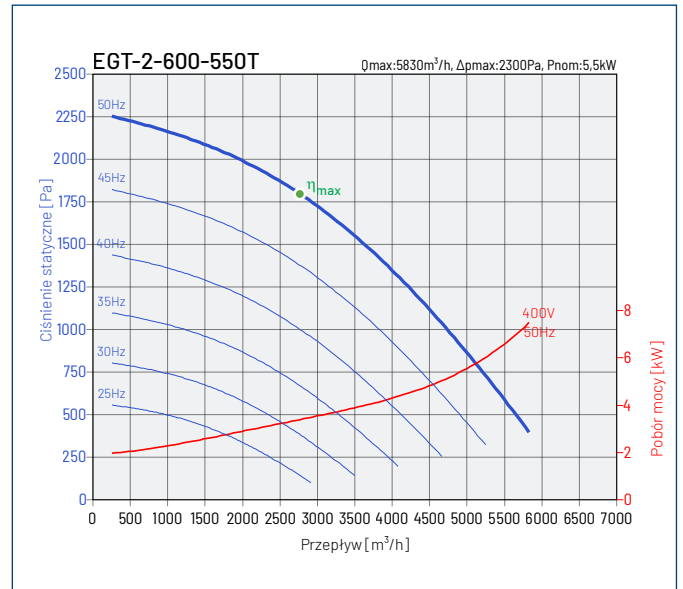
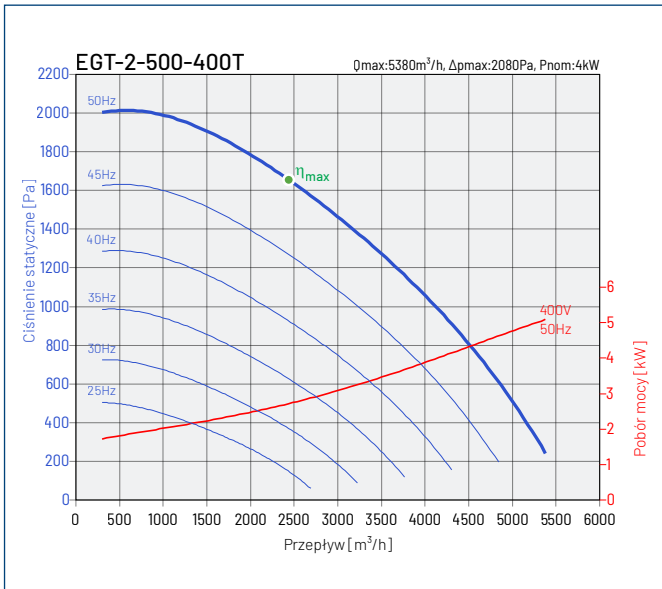
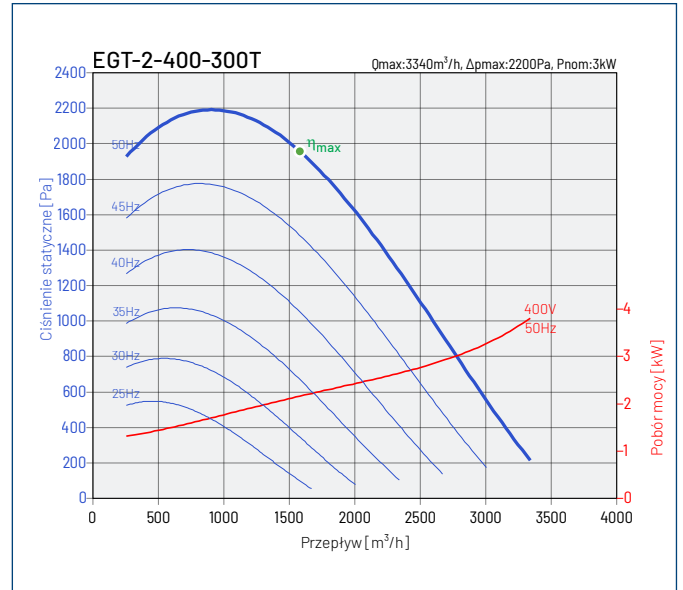
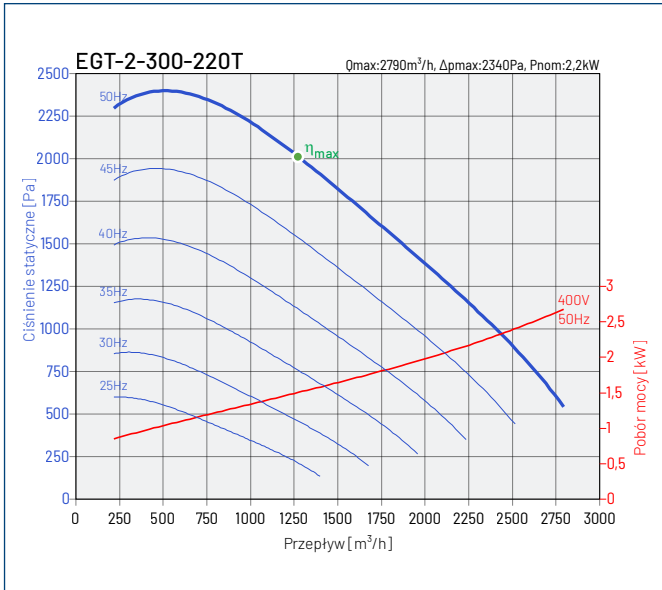

## CHARAKTERYSTYKI PRACY

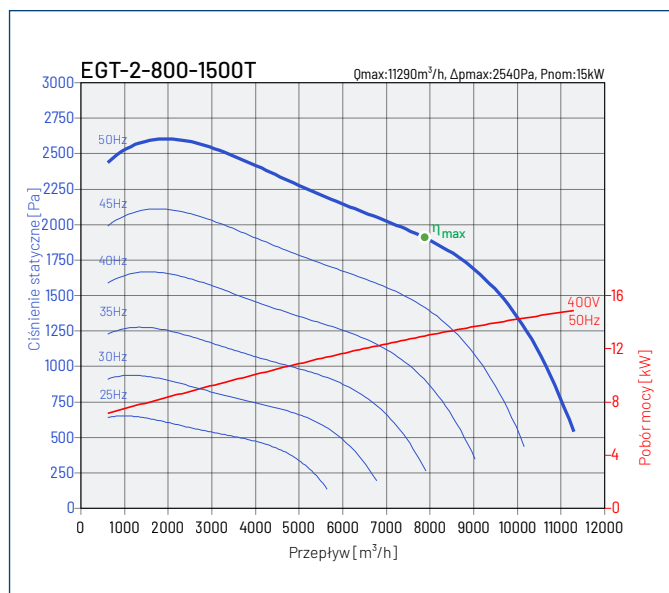

## WYMIARY [mm]

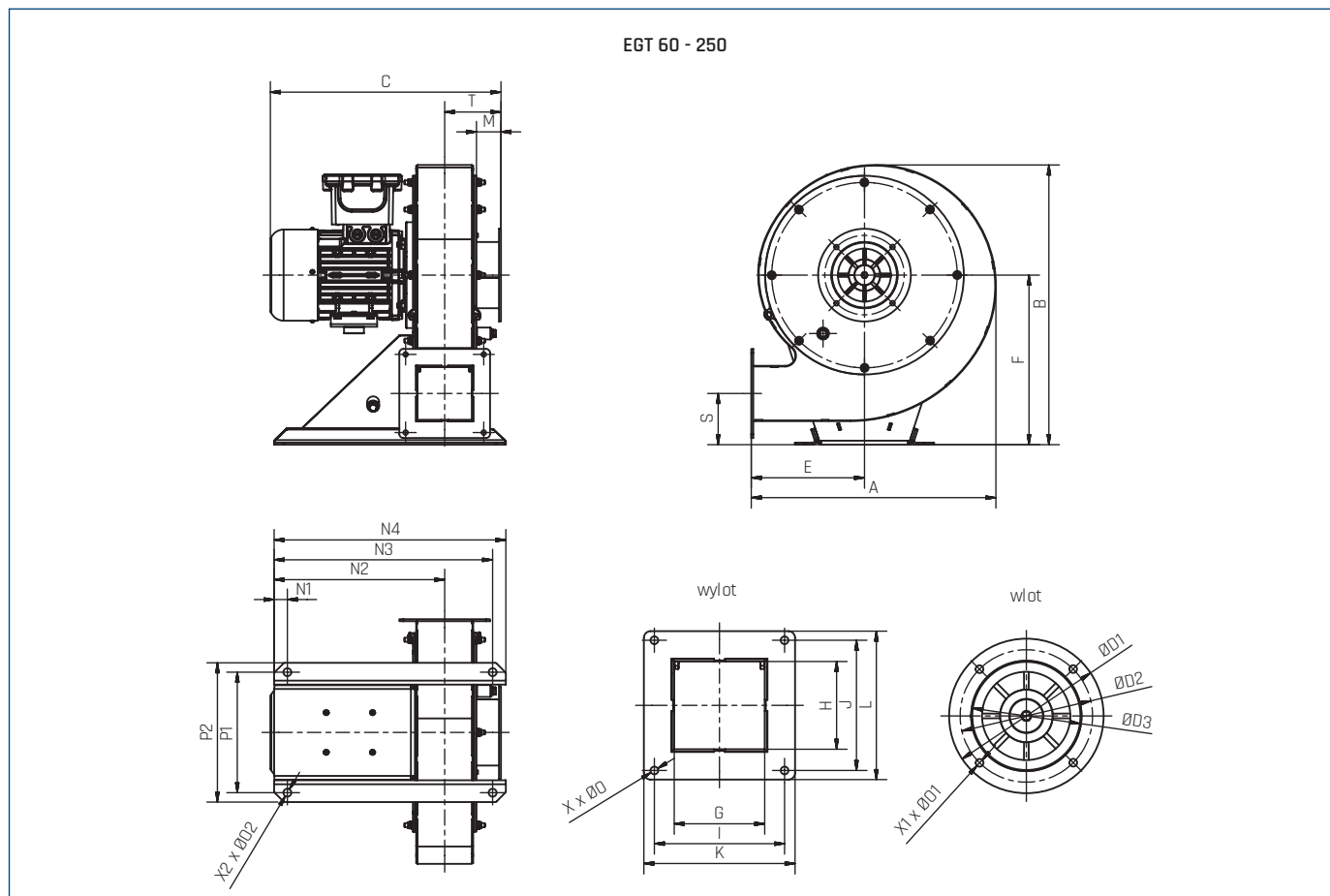

Typ	A	B	C*	ØD1	ØD2	ØD3	E	F	G	H	I	J	K	L	M	N1	N2	N3	N4	Ø0	Ø01	Ø02	P1	P2	S	T	X	X1	X2
EGT 60	369,5	422,5	348,5	140	120	98	171	256	82	79,5	118	118	137	134,5	37	20	257,5	330	350	7	7	12	182	210,5	77,5	85	4	4	4
EGT 80	367	435,5	393,5	210	185	158	172	256	127	121	163	163	182	186	37	20	280	330	350	7	7	12	182	210,5	107,5	107,5	4	4	4
EGT 100	407	472	395	210	185	158	191	276	99	99	138	138	154	154	37	20	266	330	350	7	7	12	242	270	86,5	93,5	4	4	4
EGT 130	407	472	395	210	185	158	191	276	99	99	138	138	154	154	37	20	266	330	350	7	7	12	242	270	86,5	93,5	4	4	4
EGT 200	488,5	581	409	210	185	158	223,5	343	110	139,5	150	178	167	194,5	37	20	273,5	400	420	7	7	12	294	322	110	100	4	4	4
EGT 250	488,5	581	454,3	210	185	158	223,5	343	110	139,5	150	178	167	194,5	37	20	273,5	400	420	7	7	12	294	322	110	100	4	4	4

\* wymiar C może się różnić w zależności od silnika

WYMIARY [mm]

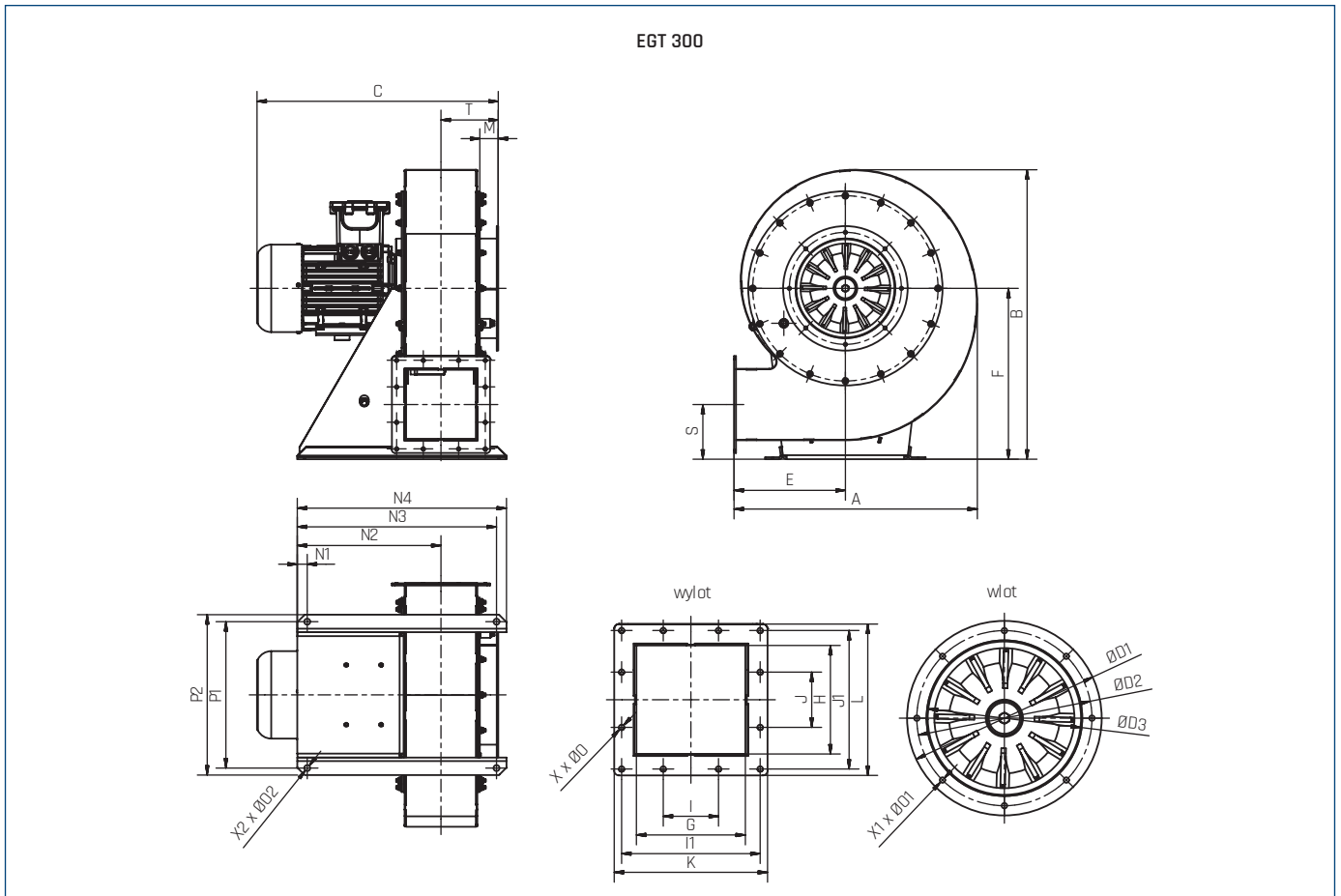

Typ	A	B	C*	Ø01	Ø02	Ø03	E	F	G	H	I	I1	J	J1	K	L	M	N1	N2	N3	N4	Ø0	Ø01	Ø02	P1	P2	S	T	X	X1	X2
EGT 300	488,5	581	484,5	250	225	197	223,5	343	140	139,5	71	178	71	178	197	194,5	37	20	288,5	400	420	7	7	12	294	322	110	115	12	8	4

\* wymiar C może się różnić w zależności od silnika

## WYMIARY [mm]

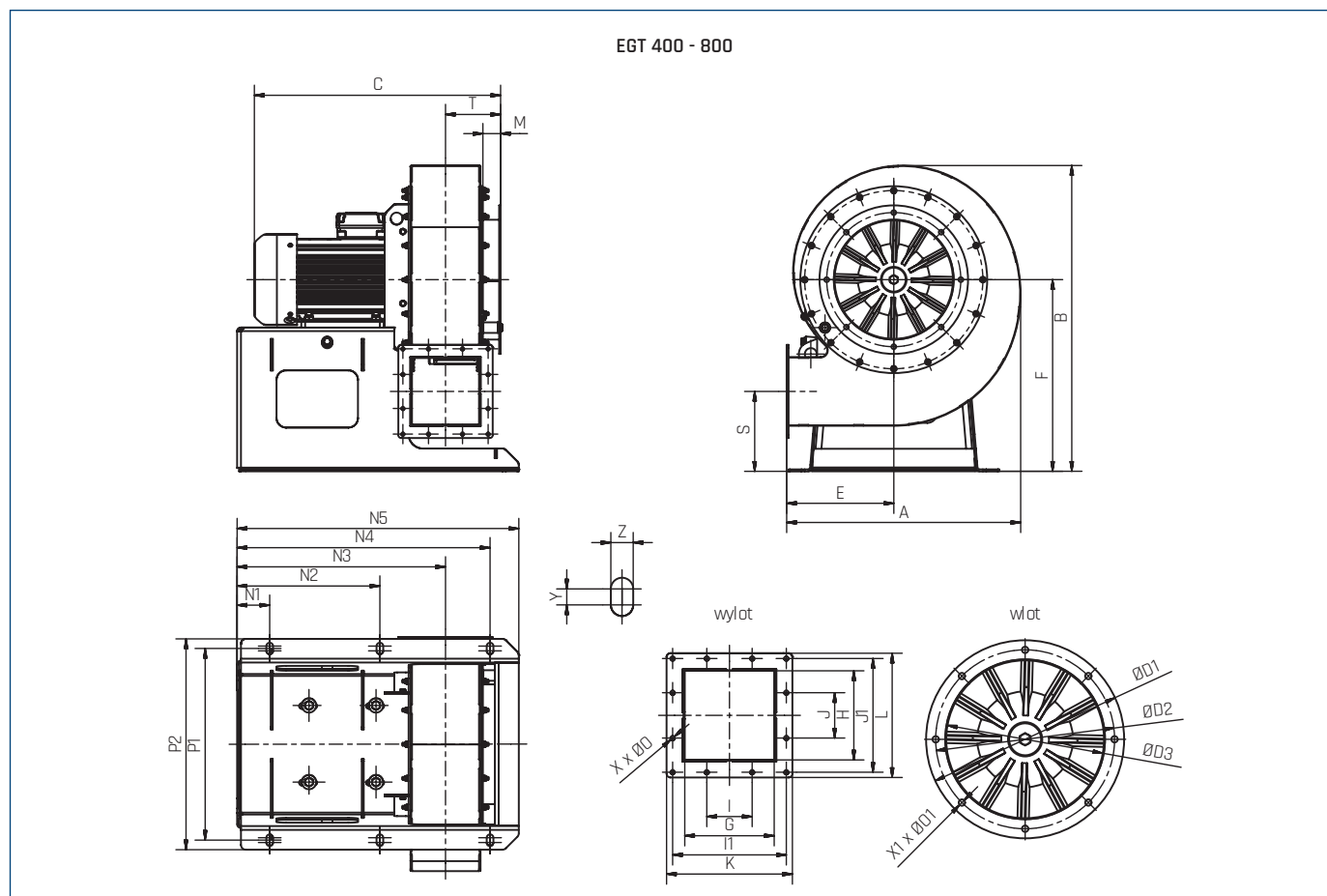

Typ	A	B	C*	ØD1	ØD2	ØD3	E	F	G	H	I	I1	J	J1	K	L
EGT 400	488,5	638	514	310	280	247	233,5	400	140	139,5	71	178	71	178	197	194,5
EGT 500	491,5	631,5	660	310	280	246	227	400	240	195	125	288	100	238	329	280
EGT 600	491,5	631,5	756,5	310	280	246	227	400	280	195	125	318	100	238	369	280
EGT 700	651,5	866	718	398	355	312	264	550	240	286	125	288	125	318	329	371
EGT 750	651,5	866	853	395	355	312	264	550	240	286	125	288	125	318	329	371
EGT 800	651,5	866	897	438	395	352	264	550	240	286	125	288	125	318	329	371

Typ	M	N1	N2	N3	N4	N5	Ø0	Ø01	P1	P2	S	T	X	X1	Y	Z
EGT 400	37	68	298	435	528	588	7	10	400	440	167	115	12	8	10	14
EGT 500	77,5	50	315	486	705	747	10	10	400	440	188	203,5	12	8	10	14
EGT 600	77,5	50	315	506	705	747	10	10	400	440	188	223,5	12	8	10	14
EGT 700	77	70	410	589	750	810	10	10	480	520	220	203,5	12	8	10	14
EGT 750	77	70	410	589	450	810	10	10	480	520	220	205	12	8	10	14
EGT 800	77	70	410	589	750	810	10	10	480	520	220	205	12	8	10	14

\* wymiar C może się różnić w zależności od silnika

## AKCESORIA MONTAŻOWE

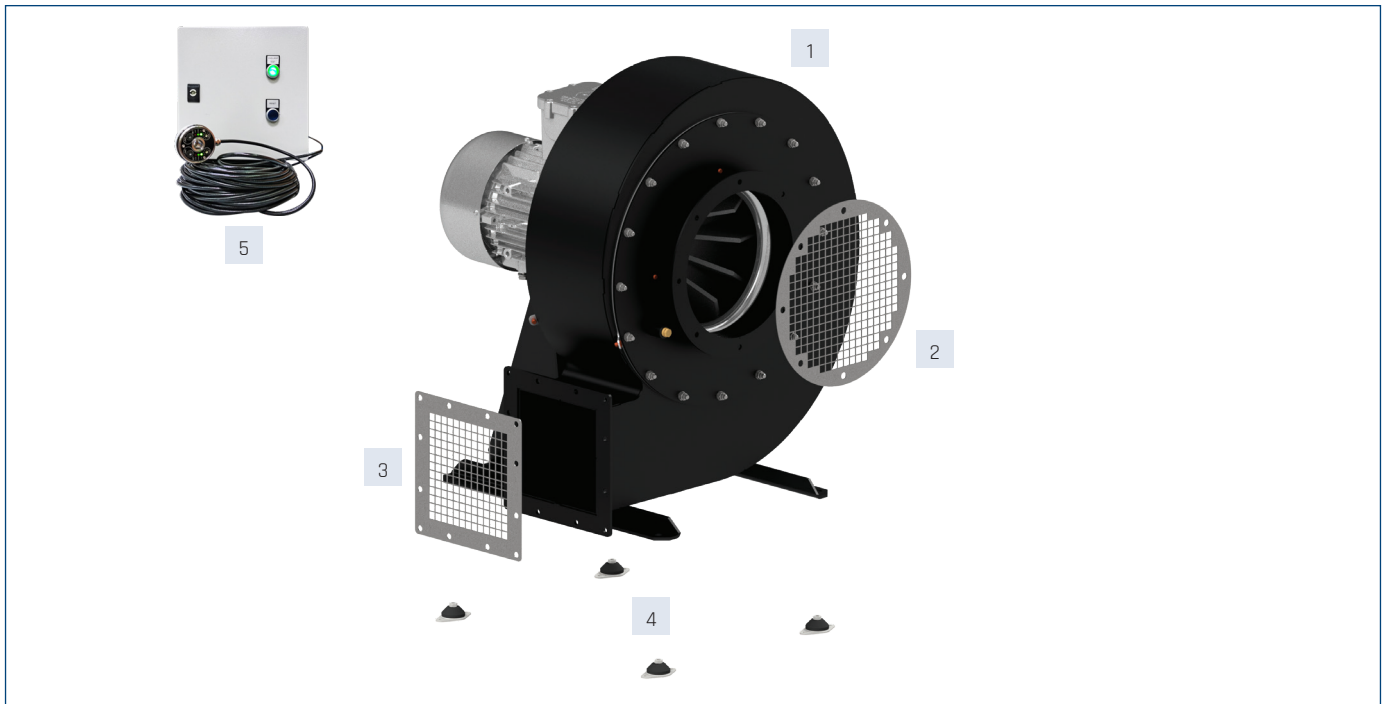

Wentylator	Ośłona wlotu (w standardzie)	Ośłona wylotu (w standardzie)	Wibroizolator	VMS - System monitorowania drgań dla stref Ex (strefa 1 i 21) z poziomem nienaruszalności
1	2	3	4	5
EGT 60	45510682-03	45510681-05	26040960	40015520
EGT 80	45510682-04	45510681-06	26040960	40015520
EGT 100	45510682-04	45510682-05	26040960	40015520
EGT 130	45510682-04	45510682-05	26040960	40015520
EGT 200	45510682-04	45510681-07	26040960	40015520
EGT 250	45510682-04	45510681-07	26040960	40015520
EGT 300	25511844	25511843	26040960	40015520
EGT 400	25511834	25511843	26040965	40015520
EGT 500	25511814	25511825	26040965	40015520
EGT 600	25511814	25511815	26040965	40015520
EGT 700	25511803	45510697	26040965	40015520
EGT 750	25511803	45510697	26040965	40015520
EGT 800	45510698	45510697	26040965	40015520





## Akcesoria elektryczne

Wentylator	Rozłącznik serwisowy	Rozłącznik bezpieczeństwa ATEX	Falownik	UEK-230
EGT-2-60-037T	R-S 3-F + SP, 16A	R-B 3-F ATEX + SP, 10A		
EGT-2-60-037T VFD	R-S 3-F + SP, 16A	R-B 3-F ATEX + SP, 10A	L 0,4 kW	U-EK230E
EGT-2-80-055T	R-S 3-F + SP, 16A	R-B 3-F ATEX + SP, 10A		
EGT-2-80-055T VFD	R-S 3-F + SP, 16A	R-B 3-F ATEX + SP, 10A	L 0,4 kW	U-EK230E
EGT-2-100-075T	R-S 3-F + SP, 16A	R-B 3-F ATEX + SP, 10A		
EGT-2-100-075T VFD	R-S 3-F + SP, 16A	R-B 3-F ATEX + SP, 10A	L 0,75 kW	U-EK230E
EGT-2-130-110T	R-S 3-F + SP, 16A	R-B 3-F ATEX + SP, 10A		
EGT-2-130-110T VFD	R-S 3-F + SP, 16A	R-B 3-F ATEX + SP, 10A	L 0,75 kW	U-EK230E
EGT-2-200-110T	R-S 3-F + SP, 16A	R-B 3-F ATEX + SP, 10A		
EGT-2-200-110T VFD	R-S 3-F + SP, 16A	R-B 3-F ATEX + SP, 10A	L 0,75 kW	U-EK230E
EGT-2-250-220T	R-S 3-F + SP, 16A	R-B 3-F ATEX + SP, 10A		
EGT-2-250-220T VFD	R-S 3-F + SP, 16A	R-B 3-F ATEX + SP, 10A	L 1,5 kW	U-EK230E
EGT-2-300-220T	R-S 3-F + SP, 16A	R-B 3-F ATEX + SP, 10A		
EGT-2-300-220T VFD	R-S 3-F + SP, 16A	R-B 3-F ATEX + SP, 10A	L 1,5 kW	U-EK230E
EGT-2-400-300T	R-S 3-F + SP, 16A	R-B 3-F ATEX + SP, 10A		
EGT-2-400-300T VFD	R-S 3-F + SP, 16A	R-B 3-F ATEX + SP, 10A	L 1,5 kW	U-EK230E
EGT-2-500-400T	R-S 3-F + SP, 16A	R-B 3-F ATEX + SP, 10A		
EGT-2-500-400T VFD	R-S 3-F + SP, 16A	R-B 3-F ATEX + SP, 10A	L 2,2 kW	U-EK230E
EGT-2-600-550T	R-S 3-F + SP, 16A	R-B 3-F ATEX + SP, 20A		
EGT-2-600-550T VFD	R-S 3-F + SP, 16A	R-B 3-F ATEX + SP, 20A	L 5,5 kW	U-EK230E
EGT-2-700-750T	R-S 3-F + SP, 16A	R-B 3-F ATEX + SP, 20A		
EGT-2-700-750T VFD	R-S 3-F + SP, 16A	R-B 3-F ATEX + SP, 20A	L 7,5kW	U-EK230E
EGT-2-750-1100T	R-S 3-F + SP, 25A	-		
EGT-2-750-1100T VFD	R-S 3-F + SP, 25A	-	L 11,0 kW	U-EK230E
EGT-2-800-1500T	R-S 3-F + SP, 40A	-		
EGT-2-800-1500T VFD	R-S 3-F + SP, 40A	-	L 15,0 kW	U-EK230E

## Numery artykułów

R-S 3-F + SP, 16A	91040908	R-S 3-F + SP, 10A	91040908-01	R-S 1-F + SP, 16A	91040907-02	R-S 3-F + SP, 16A	91040908	R-S 3-F + SP, 25A	91040910
R-S 3-F + SP, 40A	91040924	R-S 3-F + SP, 6B, 25A	91040911	R-S 3-F + SP, 6B, 40A	91040911-02	R-B 3-F ATEX + SP, 10A	44025761	R-B 3-F ATEX + SP, 20A	44025762
PRZEŁĄCZNIK BIEGÓW 0/Y/YY	91040913	L 0,4 kW	40016302	L 0,75 kW	40016312	L 1,5 kW	40016322	L 2,2 kW	40016332
L 5,5 kW	40016362	L 7,5kW	40016372	L 11,0 kW	40016383	L 15,0 kW	40016392	U-EK230E	91040958

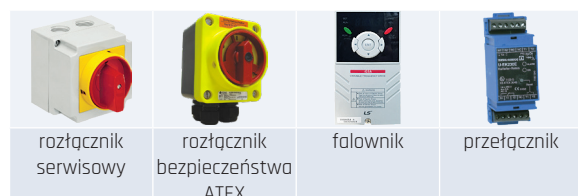

rozłącznik serwisowy

rozłącznik bezpieczeństwa ATEX

falownik

przełącznik